

VIP5: Lubrication System Controller

*Control system for small and medium size
Lubrication System*

Version SW 1.12

User Operating and Maintenance Manual

Original text translation

Warranty Information

CONTENT

1. INTRODUCTION
2. PRODUCT FEATURES
3. DESCRIPTION OF OPERATING PROCEDURES
4. FIXING AND INSTALLATION DETAILS
5. INPUTS/OUTPUTS
6. OPERATOR INTERFACE FRONT PANEL
7. OPERATING MODE
8. CYCLE MONITORING
9. SETUP PROGRAMMING
10. PROBLEMS AND SOLUTIONS
11. TECHNICAL SPECIFICATIONS
12. MAINTENANCE PROCEDURES
13. DISPOSAL PROCEDURES
14. ORDERING INFORMATION
15. MOVING AND SHIPPING
16. OPERATING PRECAUTIONS
17. WARRANTY
18. DECLARATION OF COMPLIANCE
19. DISTRIBUTORS

Manufacturer	DropsA SpA
Product	VIP5
Year	2009
Certification	

1. INTRODUCTION

Thank you for purchasing the **Dropsa VIP5 – Lubrication Controller**. This is the operating and user manual for the VIP5 Controller used to control and monitor small and medium sized lubrication system such as simple on/off systems, injector systems, progressive divider systems and simple dual line systems .

It is possible to obtain the latest documentation by visiting our website, www.dropsa.com

This manual contains important operating and safety information for users of this product. It is essential that you carefully read this manual and conserve a copy with the product so that other users may consult it at any time.

1.1 DEFINITION OF LUBRICATION AND STANDBY PHASE, LUBRICATION PHASE, AND LUBRICATION CYCLE

In this manual the **LUBRICATION PHASE** and **LUBRICATION CYCLE** refer to the specific instances when the lubrication pump is operating to provide lubrication in a system.

The **LUBRICATION CYCLE** is made up of : **Cycle Start** -> **Control** of a sensor device -> **Delay** time to allow sensor device to stabilize -> **Wait** Time before another Cycle Start. This sub-cycle can be repeated as many times as required and the completion of this repetition is considered the **LUBRICATION PHASE**. Fig. 1 Illustrates this graphically

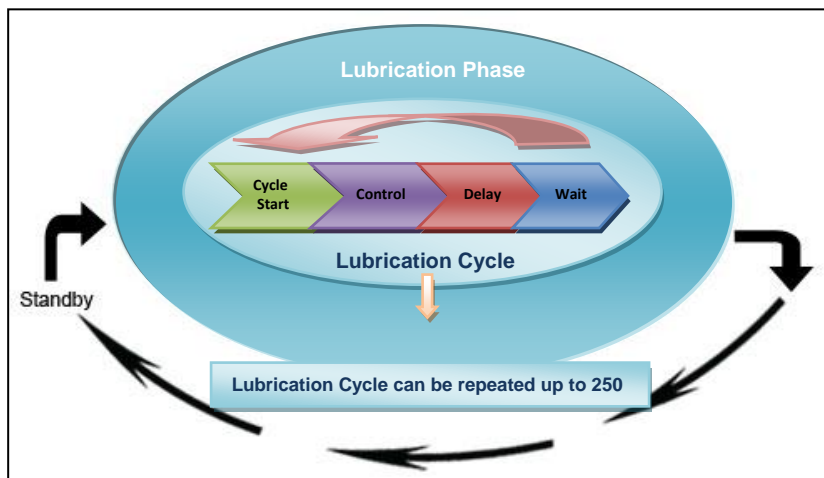

Fig.1 A Lubrication Phase can comprise of many Lubrication Cycles

The **STANDBY PHASE** defines the interval between each **LUBRICATION PHASE**.

2. PRODUCT FEATURES

VIP5 is an advanced lubrication control that offers many operating possibilities and features in a single compact package. It is an ideal product for small and medium systems as it offers considerable advantages over using a much bigger, expensive PLC system to achieve the same result. Some of the key features are:

- Three separate inputs (to monitor Dual line pressure switches, progressive cycle switch, injector pressure switch and external signals to use as a counter for standby or lubrication phase).
- Signal Inputs can be NPN, PNP or a Clean Contact (or Namur).
- Time or counter based determination of both Lubrication and Standby Phase.
- Counter based Lubrication phase can be used independently while monitoring correct function of a cycle switch, ideal for use in impulse piloted system (e.g. chain and conveyor lubrication).
- Minimum Level Input.
- 4..20ma Input for analog measurement of Reservoir Level.
- Ability to configure pump output for Electrical or pneumatic pump (pump On/Pump Off values can be set individually).
- General Alarm Output Relay can be a constant signal or generate a coded alarm to allow remote PLC to determine nature of alarm.
- Integrated LCD Display for diagnostic and ease of use.
- Diagnostic and Lubricant Counters for Operation and Alarm conditions.

All configuration parameters can be set from the Setup menu via the LCD display using the front panel keys. No complex internal switches need to be set.

3. DESCRIPTION OF OPERATING PROCEDURES

The **VIP5** controller has three operating modes: **CYCLE, PULSE or FLOW**:

CYCLE and PULSE modes are designed for intermittent or continuous lubrication system that require the control of a pump and monitoring of feedback signals to determine when lubrication has successfully completed.

FLOW is designed as a monitoring only operating mode that allows the user to monitor a pulse signal and determine the actual flow rate. This is useful for process control and generally used in re-circulating systems.

3.1 CYCLE and PULSE Control System operating Principles .

The VIP5 control system is designed to control intermittent or continuous lubrication system with a variety of control inputs. Intermittent operating principle is based on three distinct phases.

- **PRELUBE Phase** -> Pre Lubrication that occurs during power up of a system.
- **LUBRICATION Phase (Lube → Wait stages)** -> This is when lubricant is provided (as above)
- **STANDBY Phase** -> The system is inactive awaiting for the next LUBRICATION PHASE

Continuous operation is identical but does not have a STANDBY Phase.

Additionally, the VIP5 Control system can also be used as a simple monitoring device in the “FLOW” operating Mode described later in this manual.

3.1.1 PRELUBE Phase

The user can specify a number of lubrication cycles (up to 999) which are initiated when the unit is powered on. If **Prelube** is set to zero, the VIP5 controller will revert to its pre-powerdown status.

Prelube is activated:

- When the VIP5 system is powered on.
- After the RESET button is pressed.
- After the VIP5 exists from the setup menu.

As indicated above, if **Prelube** is set to “0” value, the **Prelube** phase is omitted and when the system is powered on, the system will continue from its previous position in the program.

3.1.2 LUBE (Lubrication) Phase

The Lubrication Phase is a set of Lubrication Cycles that can be repeated up to 999 times.

A Lubrication **Cycle** consists of activating the lubrication pump, then **Control** monitoring a feedback signal from a sensing device if installed. There is then **Delay** period before switching off the pump, and a **Wait** period before the lubrication cycle can be repeated. Specifically:

- **Cycle** (time) determine how long to wait for the control signal before determining an alarm condition.
- **Control** (Type) determines what kind of control signal (Single Line, Dual Line, Injectors). Alternatively a Timer only setting means no monitoring will occur.
- **Delay** (time): Is how long to wait for the signal to be confirmed and switch off the pump (in Pressure switch applications)
- **Wait** (time): determines how long to wait in a pump off condition before repeating the cycle. This is necessary in injector systems and represents the minimum time required for the injectors to reset. In progressive systems for example this can be set to zero.

3.1.3 STANDBY Phase

During the **Standby** the VIP5 switches off the pump and waits for the start of another **Lubrication Phase**. The duration of the **Standby** phase can be determined by a countdown timer or a by an external pulse signal that can be used as a counter. The VIP5 also allows a combination of both timer and external pulse signals to determine either the next Lubrication phase or to signal an alarm if external pulse signals are not received within a pre-set time.

3.2 FLOW MODE OPERATING PRINCIPLES

The VIP5 can also be used as a simple Flow monitoring system. When **Flow** mode is selected the unit operates as a flow display and monitors an external signal to calculate the flow based on external impulses. The User can additionally set a minimum and maximum Flow limit. If the flow is out of these limits, the remote alarm contact and the alarm LED on the front panel are both activated.

4. FIXING AND INSTALLATION DETAILS

FIXING DIAGRAM

The different VIP5 models are shown below with fixing dimensions.

VIP5 Plastic Box

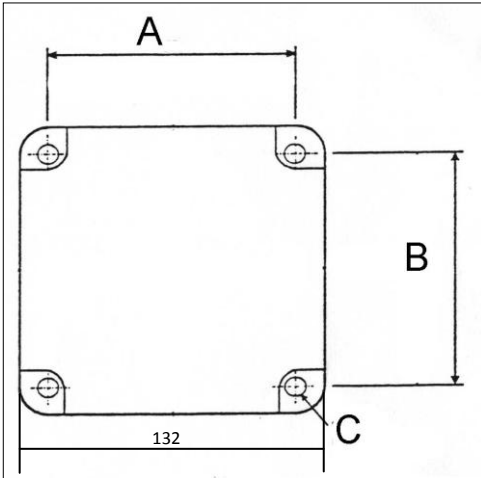

PN: 1639140 / 1639141 / 1639142

A	B	C
95 mm (3.7 in.)	95 mm (3.7 in.)	Ø 4,2 mm (Ø 0.16 in.)

VIP5 Panel Mount

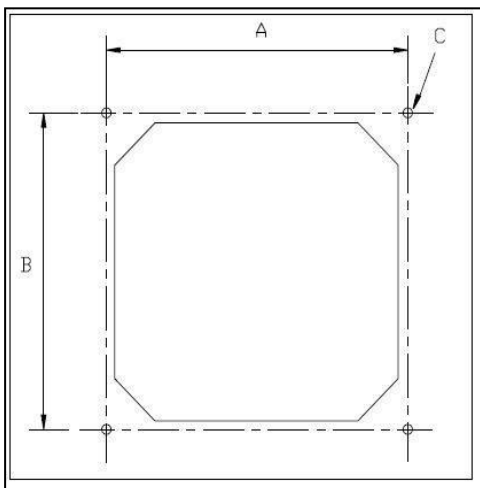

PN: 1639144 / 1639145 / 1639147

A	B	C
111,5 mm (4.4 in.)	111,5 mm (4.4 in.)	Ø 3,5 mm (Ø 0.13 in.)

VIP5 Steel Box

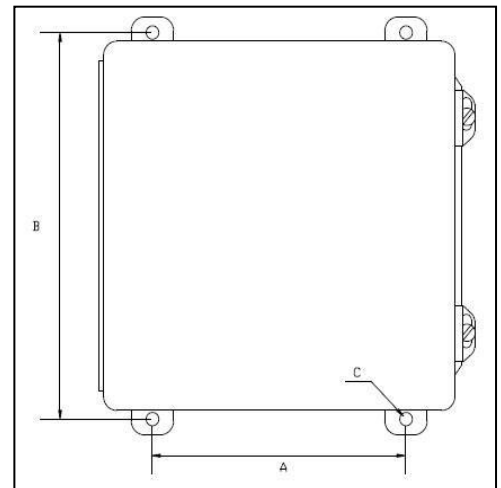

PN: 1639150 / 1639151 / 1639152 / 1639153

A	B	C
153 mm (6 in.)	222 mm (8.75 in.)	Ø 8 mm (Ø 0.13 in.)

4.1 UN-PACKING

Once the installation point has been identified, you can unpack the VIP5 from its shipping box. Check that the unit has not been subject to any damage during transport. Dispose of the packaging in an appropriate manner, following local waste regulations.

4.2 INSTALLATION

The VIP5 must be secured physically to a mounting location and cabled to all the required components of the lubrication system.

The following are general recommendation:

- Install the unit in an easy to access location so that users can avoid unnatural postures and have good visibility of the display.
- Leave 100mm or 4 inches around the unit of space to facilitate cabling and maintenance.
- Do not install the unit in dangerous or excessively aggressive environments with high levels of vibration or in the vicinity of flammable substances.
- Always use the four fixing points as indicated in the diagram.

5. INPUTS/OUTPUTS

5.1 ELECTRICAL CONNECTIONS

The input and output connections for the lubrication devices and sensors can be achieved via the M1 and M2 terminal strip located on the bottom of the VIP5 box.

The following are connection information for the M1 and M2 terminal strips.

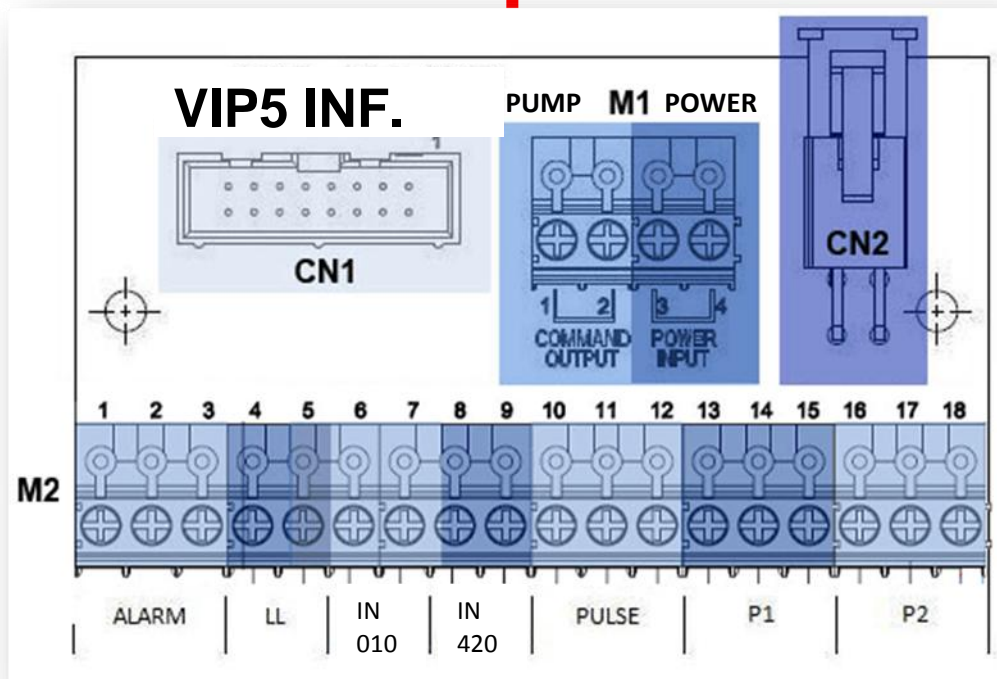
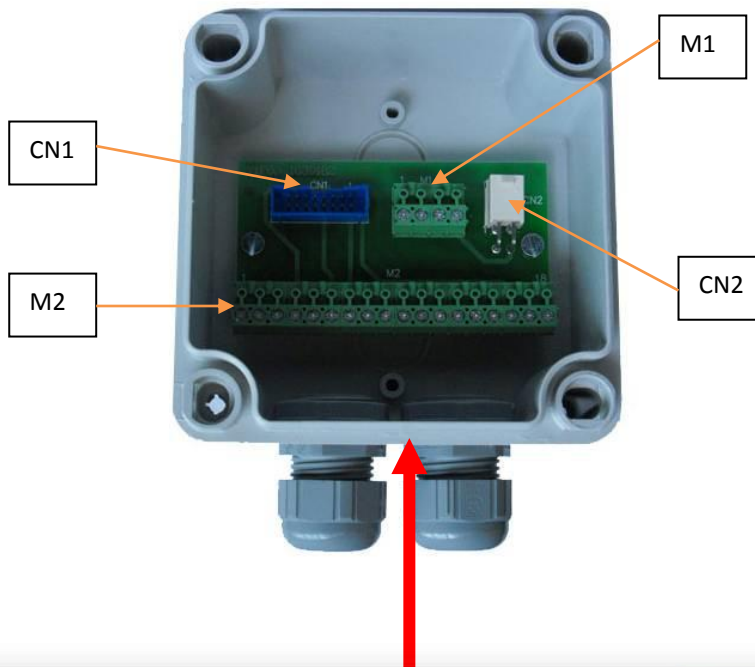

The following table lists INPUTS and OUTPUTS for the VIP5

Location		TYPE	PINOUT LABEL	DESCRIPTION	NOTES
Terminal	Number				
M1	1	Output	Motor line 1 (+)	Pump/Solenoid Connection	max 10A @ 230V~ Power is supplied via relay from pins 3 and 4
M1	2		Motor line 2 (-)		
M1	3	Input	Power AC/DC input 1 (+)	POWER CONNECTION FOR VIP5	12V/24V/110V/230V Depending on Model purchased.
M1	4		Power AC/DC input 2 (-)		
M2	1	Output	Alarm contact common	Remote alarm relay	max 2A @ 30V ~
M2	2		Alarm contact NC		
M2	3		Alarm contact NO		
M2	4	Input	LL	Minimum Level Sensor	Open contact, or PNP,NPN,NAMUR (*see Note 1)
M2	5		GND		
M2	6	Input	IN010	0-10V Volt analog input	Not used
M2	7		Analog GND		
M2	8	Input	IN 420	4-20 mA analog input connection point	Not isolated
M2	9		Analog GND		
M2	10	Input	+Ve (see Note 2)	Input for external counting device. PNP/NPN or clean contact.	Clean contact, PNP,NPN,NAMUR (*see Note 1)
M2	11		PULSE		
M2	12		GND		
M2	13	Input	+Ve (see Note 2)	First Sensor Input for monitoring system. Eg. Pressure switch for injectors or Cycle switch for progressive system	Clean contact, PNP,NPN,NAMUR (*see Note 1)
M2	14		P1		
M2	15		GND		
M2	16	Input	+Ve (see Note 2)	Second Input for monitoring system. Eg second pressure switch on a dual Line System	Clean contact, PNP,NPN,NAMUR (*see Note 1)
M2	17		P2		
M2	18		GND		

*Note 1: If using NAMUR wire sensors, a 1.5kΩ to 2.5kΩ resistor should be installed between Signal and GND (see paragraph 6.1 for wiring diagram)



Note 2 : for active sensors, the maximum current available is 100mA in total on +Ve. When using clean contacts, the VIP5 will use 12 or 24V to monitor the contact.

5.2 WIRING EXAMPLES

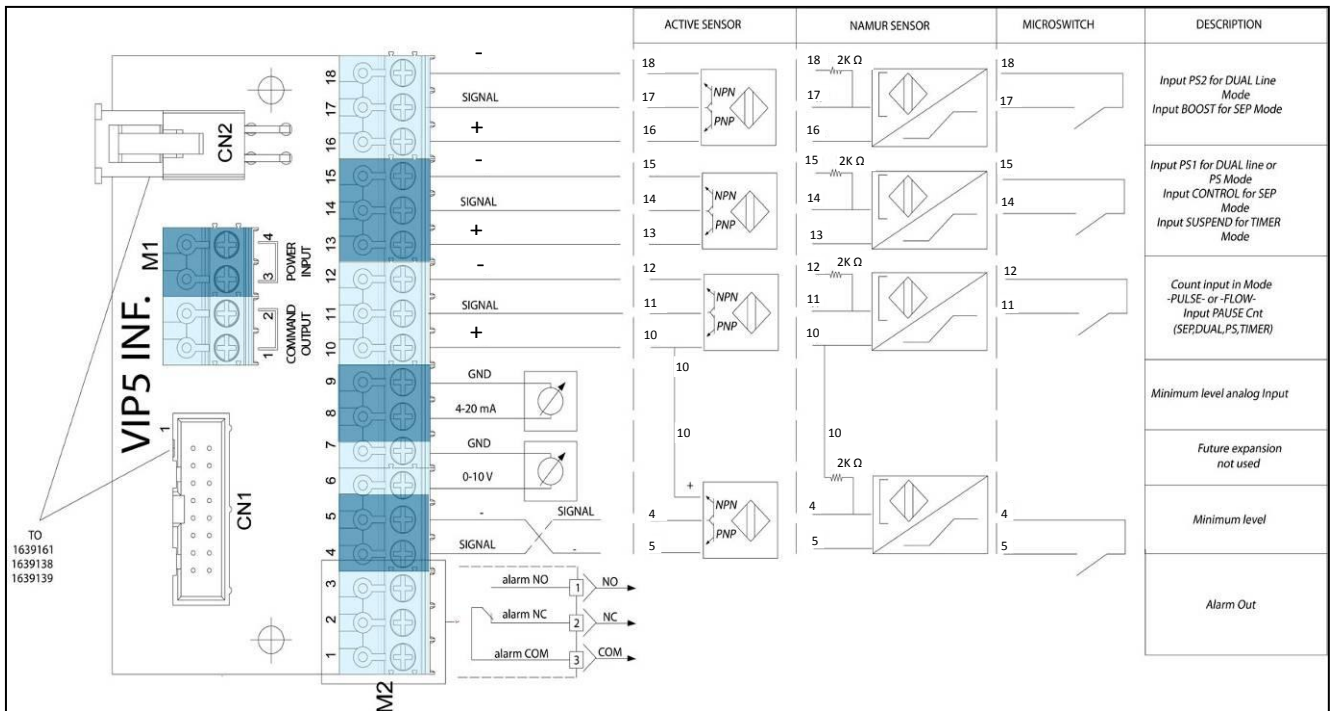

5.3 ACTIVATING THE BATTERY FOR REAL TIME CLOCK FUNCTIONS

JUMPER:
Bridge pins to activate battery

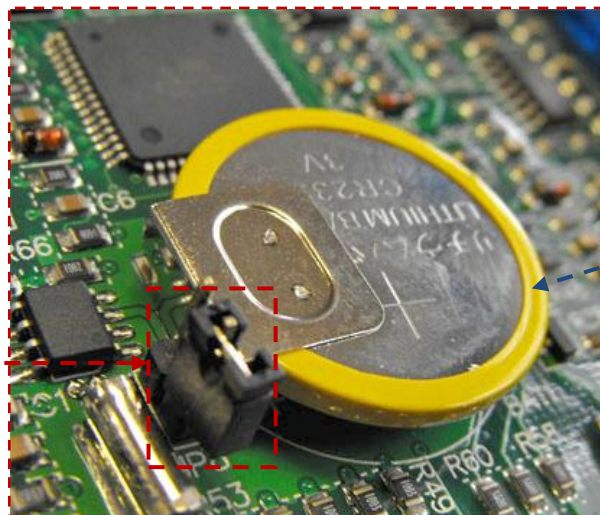

BATTERY

By inserting the Jumper into the bridging pins, the battery function is activated and this allows the **VIP5** to operate with the Date/time and status save function when the power is removed.



Note: Every time the battery jumper is removed and reinserted causes the DATE/TIME function to be set to zero. Therefore it is recommended that after inserting the battery jumper, the date and time is set.

5.4 PRECAUTIONS TO BE USED WHEN CARRING OUT WIRING

There are no specific safety risks associated with this device. Use general precautions that you would use when operating an electrical device. All wiring should be carried out by a qualified electrician.

- Before wiring the panel ensure correct voltage as indicated on the product label.
- Only perform wiring operations once you are sure power is off and cannot be accidentally switched on.
- A circuit breaker that is easy accessible must be used in the wiring of the pump. Ensure the break contact has a contact distance of at least 3 mm
- When using the 12-24V AC device, the power must come from a transformer in compliance with prescription of IEC 62558-2-6
- In case of connection to 230 V~ or 110 V~, the connections on M1 (power and pump) must have reinforced isolation up to the terminal connections. The cable must be routed to avoid damage to the outer isolation sheaf.
- It is advisable to use a fuse or a differential isolation to protect the device. The device should have a recommended value of 0,03 Ampere with 1 second maximum activation time. isolation capability $\geq 10\text{kA}$ and nominal $I_n=6\text{A}$.
- It is good practice to use cable ties that can help prevent cables being torn

6. OPERATOR INTERFACE FRONT PANEL

6.1 LAYOUT AND STATUS TABLE OF VIP5 FRONT PANEL

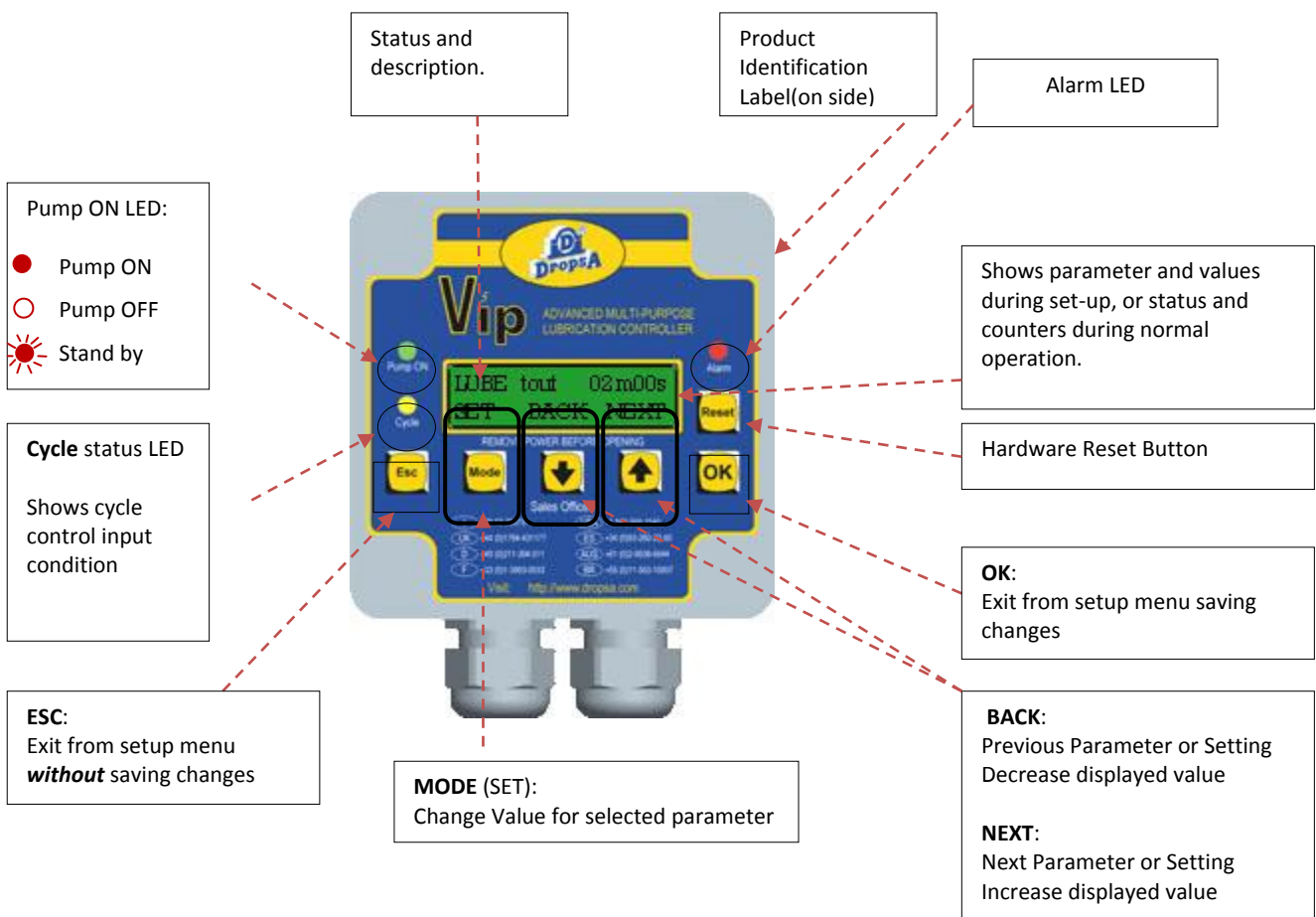

VIP5 Condition	PUMP ON LED	CYCLE INPUT LED	ALARM LED
Alarm	OFF	ON	ON
Standby Phase	OFF	ON	OFF
Lubrication Phase/Cycle	ON	ON	OFF
Setup	OFF	OFF	ON

7. OPERATING MODE

VIP5 has three different operating modes which are determined during the setup stage described previously. These are: **CYCLE**, **PULSE** and **FLOW**.

7.1 CYCLE Mode

In *Cycle* mode a cycle sensor determines the completion of the LUBRICATION PHASE. If using timer setting, the Lubrication Cycle will complete when the timer expire. The Standby phase is determined by a timer or by an external input counter.

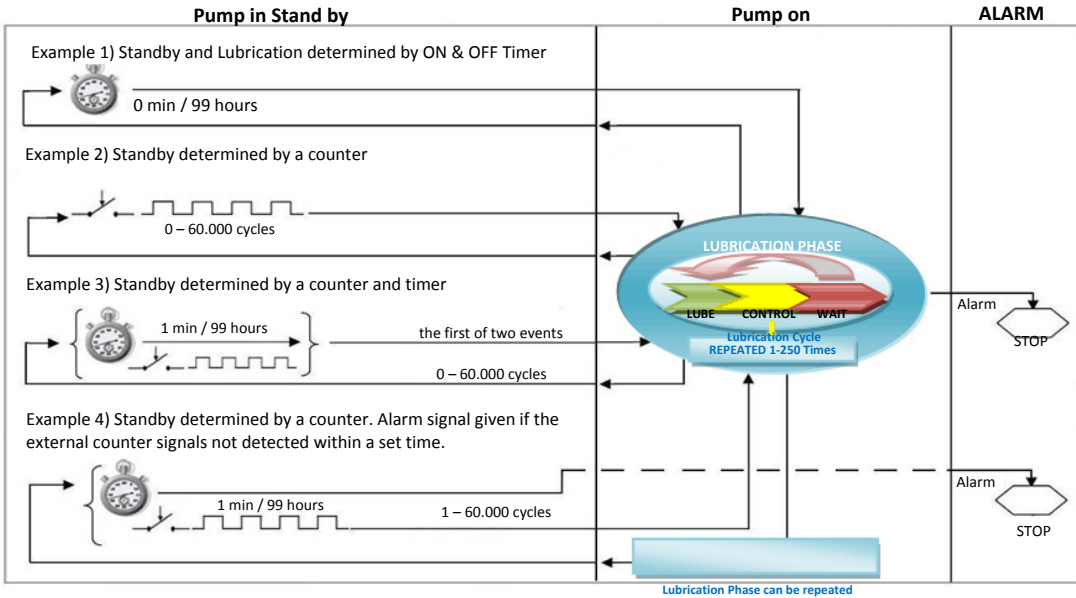

7.2 PULSE Mode

In *Pulse* mode, the duration of the **Standby Phase** and the **Lubrication Phase** are both determined by an external counter. The correct operation of the **Lubrication Cycle** can be monitored using a cycle sensor.

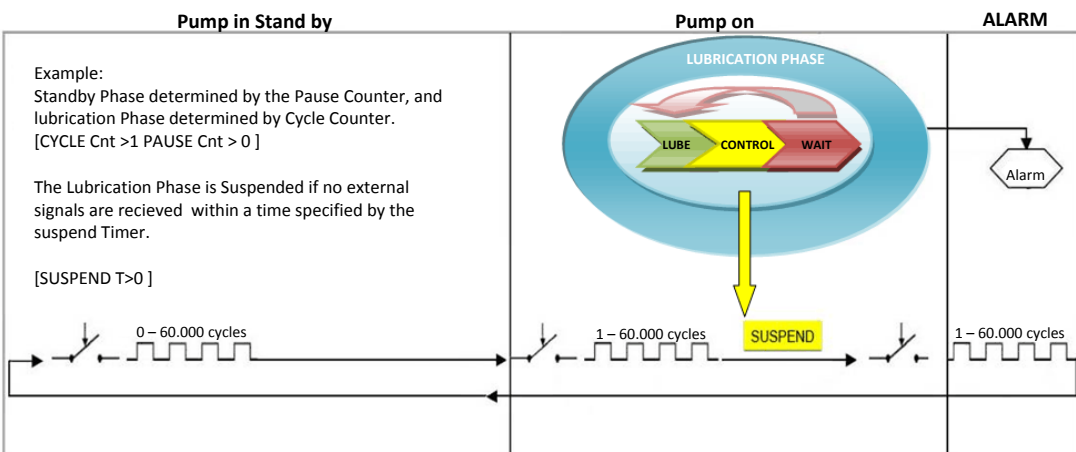

7.3 FLOW Mode

Using this mode allows the VIP5 to be used as a simple flow monitoring and display device.

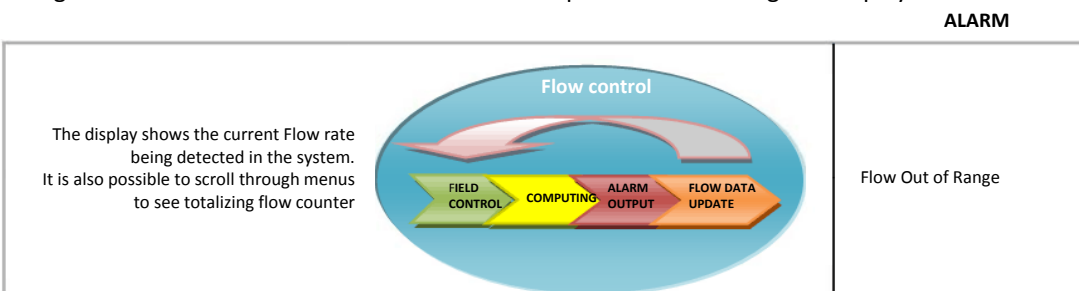

7.4 PRELUBE

The Prelube cycle is a pre-lubrication cycle that is triggered when the system is powered on or reset. If the pre-lube cycle value is set to 1 or greater the VIP5 will perform the set number of **Lubrication Phases**.

Note that if Each **Lubrication Phase** comprises two or more **Lubrication Cycles**, then the total cycles performed will be equal to the **Lubrication Cycles** multiplied by the **Prelube Cycles**.

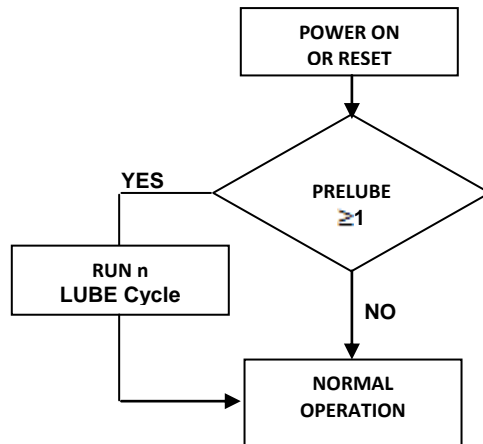

8. CYCLE MONITORING

8.1 MONITORING OPTIONS.

There are four possible Cycle Monitoring Options, explained below.

1) TIMER – TIME ONLY

The Lubrication cycle is simply operated according to a preset Timer value.

Therefore, **no input is monitored** to confirm the correct completion of the lubrication cycle.

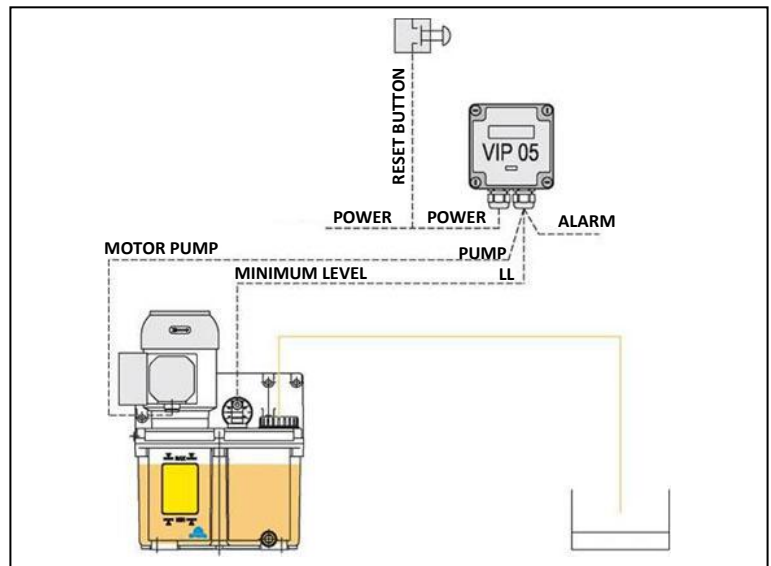

2) PS – PRESSURE SWITCH

Pressure switch monitoring is typically used in injector system.

The **VIP5** will monitor input **P1** to verify that it is an **OPEN** contact at the start of the cycle.

The pump is activated and the pressure switch must **CLOSE** within a timeout period otherwise a cycle alarm is generated.

Once the **P1** contact is closed, a **DELAY** timer checks that the switch is not broken for a set time before switching off the pump. This ensures that pressure spikes at the start of a lubrication cycles on long lines are filtered out.

A **WAIT** timer can be set to allow the injectors to reset when using multi cycle configuration.

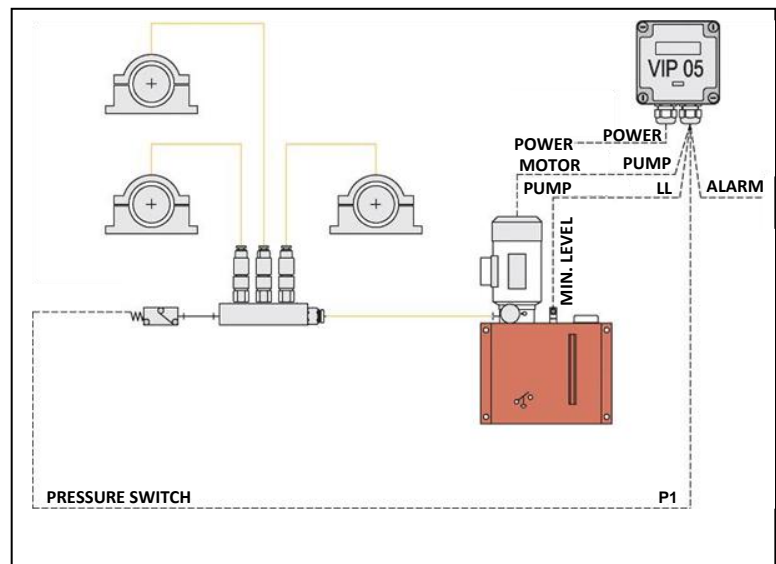

3) SEP – SERIES PROGRESSIVE

Series progressive Operating mode is used for Cycle switch monitoring typically on progressive systems.

The Pump is switched on and P1 input is monitored and must change state twice within the timeout period otherwise a timeout alarm will be generated.

Once P1 changes state twice, the pump is switched off and VIP5 goes to standby or the Lubrication Cycle is repeated for the desired number of times

There is no WAIT time in this mode as progressive systems do not need venting time.

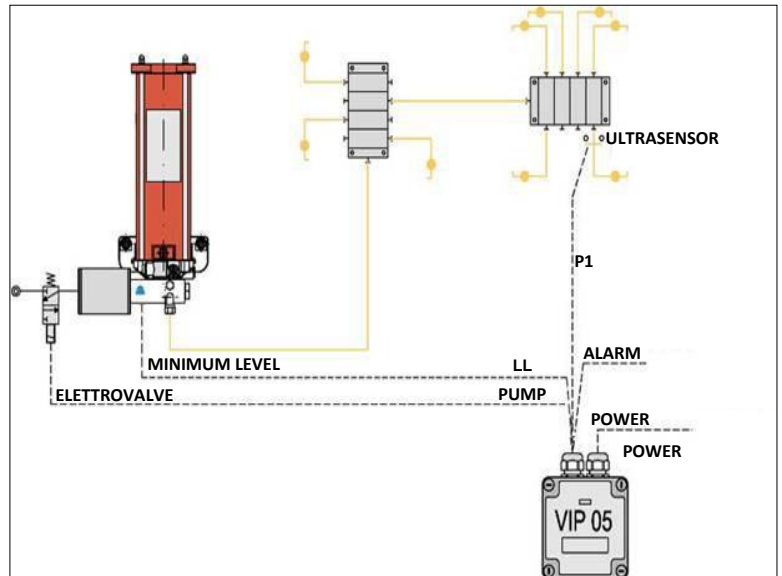

4) DL – DUAL LINE

Dual Line cycles generally use two pressure switches connected to **P1** and **P2**.

The **VIP5** starts the pump and must see that **P1** switch is closed within the timeout time. After this, the Lubrication lines are inverted by use of a directional valve.

The **P2** switch must also then be made within the timeout timer setting.

A user configurable **DELAY** timer can be set to filter pressure spikes as in the **PS** operating mode.

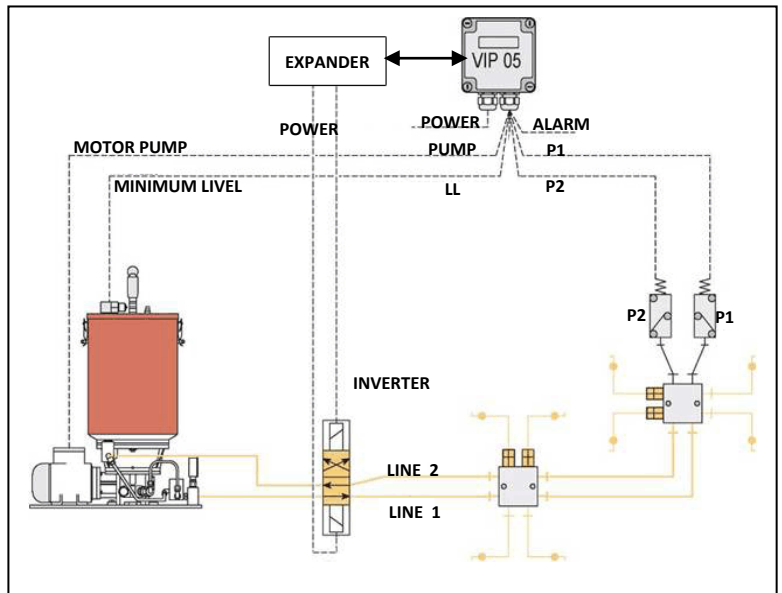

8.2 NOTES ON CONTROLLING A DIRECTIONAL VALVE IN A DUAL LINE SYSTEM:

When using hydraulic dual line system directional valves the pressure itself causes the valve to perform the line inversion.

However, if using an electrically operated directional valve then a signal must be given to power the solenoid that causes the valve to invert.

The VIP5 already has this control capability, but you must fit the expander Terminal Wiring board in order to have the output present to power the solenoids.

9. SETUP PROGRAMMING



The following section explains how to navigate the **VIP5** setup menus and contains detailed explanation of each parameter and possible values.

9.1 Navigating around the setup menu.

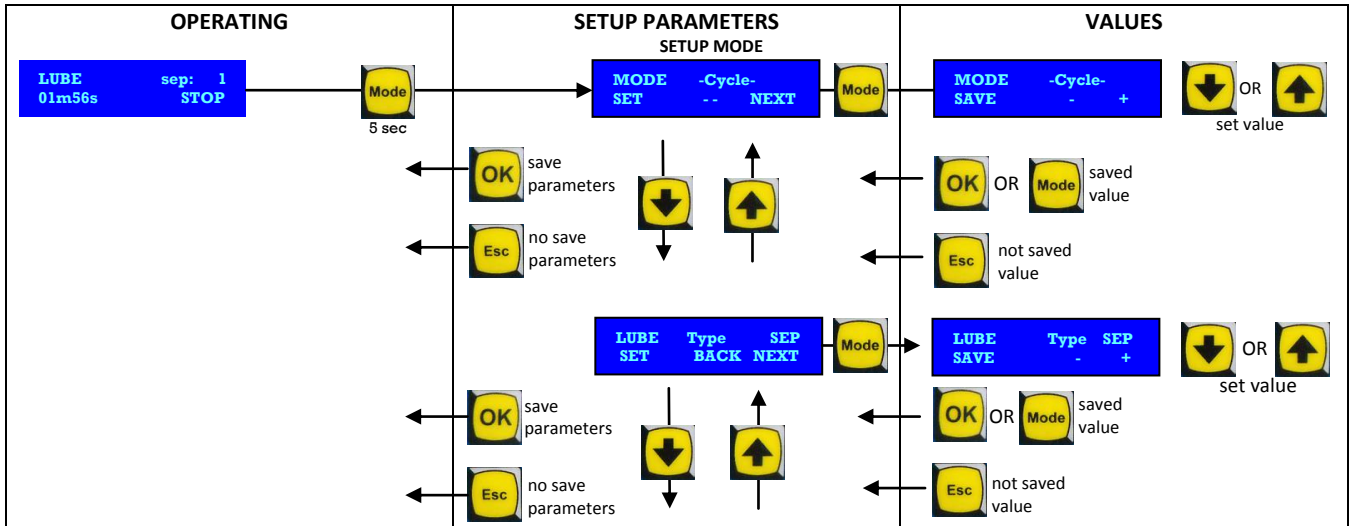
The navigation map below shows how to navigate around the setup menu.



To enter the SETUP menu from the OPERATING Mode, hold the  (Mode) button for 5 seconds.

The   (Up and Down) keys allow scrolling through the parameters.

By pressing the Mode button again, the indicated parameter value can be modified by using the Up and Down keys.

To exit, use the  (OK) key, or  (Esc) if you wish to exit without saving

9.2 PARAMETERS AND VALUES.

The following table explains the parameters and possible values of the VIP5. The first two Parameters (**MODE** and **TYPE**) determine what parameters are available in the menu and should therefore be set first.

PARAMETER NAME	DEFAULT VALUE	DESCRIPTION	VALUES/RANGE	APPLICABILITY						
MODE	CYCLE	SELECTS THE OPERATING MODE:								EXPANDER ONLY
		Flow monitoring mode	FLOW							
		Lubrication Cycle completed when the cycle sensor confirms correct lubrication	CYCLE							
		Both Standby and Lubrication Phase determined by external signal.	PULSE					PULSE	CYCLE	FLOW
TYPE	SEP	SELECTS THE CYCLE MONITORING:						X	X	
		Timer only	TIMER							
		Pressure switch	PS							
		Progressive Cycle switch	SEP							
		Dual Line Pressure switches	DUAL	DUAL	SEP	PS	TIMER			
CYCLE TOUT	2 min	Timeout counter determines how long to wait for cycle completion before a timeout alarm is generated.	1s-1h	X	X	X		X	X	X
LUBE TIME	2 min	In timer Mode, how long the pump will run.	0s – 99h				X		X	
CYCLE CNT	1	The Duration of the Lubrication cycle (in PULSE Mode)	1-60000	X	X	X	X	X		
DELAY TIM	5s	When a Pressure switch is made, how long to keep the pump running to ensure the signal is genuine and not a pressure spike.	0s – 2min	X		X		X	X	
		In Flow Mode: time an alarm condition must exist before being reported.								X
SUSPEND T	1s	In Pulse Mode, will suspend the Lubrication Phase if a signal is not received.	Null – 2min	X	X	X	X	X		
PAUSE CNT	1	Counter for standby phase (PULSE input). See also: PAUSE MULTIP.	Null – 250 (cycle mode) Null-6000 (PULSE mode)	X	X	X	X	X	X	
SUSPEND	Never	In Cycle mode, a remote SUSPEND can be enable by closing the <i>Pulse Input</i> . Setting In Pause causes the current lubrication cycle to complete before entering a remote Suspend state	Never, In Pause In Cycle, Always	X	X	X	X		X	
PAUSE BY	Timer	DETERMINES STANDBY PHASE TIMING								
		Time based Standby	Time							
		A set number of external PULSE signals	Counter	X	X	X	X		X	
		Whichever of above 2 events occurs first.	Time & Counter							
		By PULSE signals. However, if PAUSE TIM. is reached, an alarm will be given	Tout & Count							
PAUSE TIM.	6m 00s	Standby Timer setting. Null means the standby phase will be skipped	Null – 99h 00m	X	X	X	X		X	
PUMP	Continuous	Pump output can be constant signal or pulsed signal (see next 2 parameters)	Continues, Pulsed	X	X	X	X	X	X	
PUMP TON	5.0	Sets the ON value of the pump pulse.	0.1-25.0s	X	X	X	X	X	X	
PUMP TOFF	5.0	Sets the OFF value of the pump pulse.	0.1-25.0s	X	X	X	X	X	X	
PAUSE MULTIP.	1	Multiplies the Pause setting by a factor of 10 or 100 to achieve higher settings. See also: PAUSE CNT	1; 10; 100	X	X	X	X	X		
LUBE CYCLES	1	Number of Lubrication Cycles to complete a Lubrication Phase	1 - 250	X	X	X	X		X	
BOOST CYCLES	1	In a SEP mode, If P2 input is closed the LUBE CYCLES values is increased by this value contained in this setting	0 - 255		X				X	

				DUAL	SEP	PS	TIMER	PULSE	CYCLE	FLOW	EXPANDER ONLY
PRELUBE	0	Number of Prelube Cycles	0 - 250	X	X	X	X		X		
WAIT TIME	10s	Time between two Lubrication Cycles within the Lubrcation Phase	Null - 2 min	X	X	X	X		X		
START IN	Resume	Determines state at power on:		X	X	X	X	X	X	X	
		Start in Lubrication Phase	Lube								
		Resume from power down state	Resume								
FLOW VALUE	1,0	Informational value of how much lubricant is dispensed per Lubrication Cycle	0.0 - 1000	X	X	X	X	X	X	X	
UNITS	Counts	Information Unit for the flow value parameter used for display purposes only.	Counts, CubicC., Liters, Pints, Gallons, Kilos, Grams	X	X	X	X	X	X	X	
FLOW MIN	10,0	Minimum Flow Setting Totally excludes flow alarm if null	0.0 - 6000							X	
FLOW MAX	100,0	Maximum Flow Setting	0.0 – 6000							X	
ALARM	Standard	How REMOTE ALARM is managed;		X	X	X	X	X	X	X	
		Relay is powered off during alarm	Standard								
		Relay is powered On during alarm	Inverted								
		A Pulse Coded Alarm signal is given	Coded								
STOP	On None	Determines what Alarm conditions should stop the VIP5 Lubrication cycles.		X	X	X	X	X	X		
		Never stop the Lubrication cycles	On None								
		All alarm conditions	On All								
		All but min Level stops the Vip5	All But Min Level								
MIN. LEV. INPUT	NC	Configuration for the input signal of minimum level	NC, NO, 4-20mA	X	X	X	X	X	X		
LO LEVEL MA	19,8	Setting a low level if you use 4-20mA input	4.0 – 20.0	X	X	X	X	X	X		
HI LEVEL MA	4,2	Setting a high level if you use 4-20mA input	4.0 – 20.0	X	X	X	X	X	X		
HI LEVEL IN	No	What kind of input to use for High reservoir level monitoring	NC , NO	X	X	X	X	X	X		X
MININPUT DELAY	0,5s	When resetting a low level alarm, grace period before monitoring level inputs.	0s-5s	X	X	X	X	X	X		
THERMAL INPUT	NO	Type of signal used to read the THERMAL RELAY TRIP input.	NC, NO	X	X	X	X	X	X		X
FILL TOUT	0s	Maximum waiting time for filling operations	0s-2min	X	X	X	X	X	X		X
AIR DELAY	5s	Time delay to leave air relay active after Lubrication Cycle finished	Null – 2m	X	X	X	X	X	X		X
DATETIME	Disable	Enable or Disable the Real Time clock functions. Note: be sure battery is connected.	Enable, Disable	X	X	X	X	X	X	X	
DAY	1	DateTime: Day setting	1 – 31	X	X	X	X	X	X	X	
MONTH	1	DateTime: Month setting	1 – 12	X	X	X	X	X	X	X	
YEAR	2000	DateTime: Year setting	2000 - 2099	X	X	X	X	X	X	X	
HOUR	0	DateTime: Hour setting	0 – 23	X	X	X	X	X	X	X	
MINUTE	00	DateTime: Minute setting	0 – 59	X	X	X	X	X	X	X	
SET DEFAULT VAL.		RESET TO FACTORY DEFAULT SETTINGS	Yes – No	X	X	X	X	X	X	X	

9.3 SPECIAL FUNCTIONS:

1) **LCD CONTRAST ADJUSTMENT :**

By Pressing ESC or OK during power on or immediately after a reset, you access the menu for adjusting the contrast of LCD; hold down OK the contrast decreases, with ESC increases.

2) **FLOW TOTALIZER DATA VISUALIZATION:**

With the VIP5 in standby mode, pressing the OK key will allow you to scroll through the current average flow rate, or the total volume dispense in the last DAY, HOUR or TOTAL since last reset.

3) **RESETTING THE FLOW TOTALIZER:**

During the visualization of the above parameters the flow can be reset by holding the DOWN key.

4) **TIME AND DATE:**

During standby, it is possible to view time and date by using the ESC key only if DATETIME parameter is set on "enable".

5) **EVENT LOG VIEWER:**

By holding the Up or Down key for five seconds it is possible to scroll through the Event Log . (available in version FW 2.xx onwards)

10. PROBLEMS AND SOLUTIONS



ATTENTION: The VIP5 should only be repaired by qualified Dropsa technicians.

10.1 ALARM CODE TABLE

The following is a list of possible alarms generated by the VIP5 with information for troubleshooting purposes.

ALARM CODE	DESCRIPTION	NOTES/CHECKS/SOLUTIONS
ALARM 01	LOW LEVEL	The Low level sensor has triggered. Replenish the oil reservoir.
ALARM 02	CYCLE TIMEOUT	The cycle switch has not been detected in the specified time. Make sure that you have set the timer to a value that allows the cycle to complete.
ALARM 03	BOOST WARNING	The P2 input has been activated and the Boost Function has increased the number of Lubrication Cycles in the Lubrication Phase.
ALARM 04	THERMAL PROT.	The Thermal relay trip signal has been detected. Verify and repair.
ALARM 05	PS ALREDY ON	In PS Cycle mode, the pressure switch was already active before the pump was switched on. Check to ensure the venting system is operating correctly.
ALARM 06	PS AFTER WAIT	In PS Cycle mode, the Pressure switch cannot achieve pressure for the duration of the DELAY time parameter. Check parameters are correct and the pump is operating correctly and can maintain pressure.
ALARM 07	NOT IN PRESS.	No Pressure switch detected within the timeout time. Verify pump and pressure switch are operating correctly and there are no leaks.
ALARM 08	PAUSE TIMEOUT	In TOUT & Count Mode, no external signal has been received for the Timeout period setting. Verify external switch is operating.
ALARM 09	HI LEVEL	MAX level is present in tank.
ALARM 10	BAD SET 420MA	Programming error on the 4-20 mA input, modify parameters to have a range MIN-MAX >4mA
ALARM 11	BAD IN 420MA	Incorrect wiring on the 4-20 mA, signal underrange or overrange
ALARM 12	LO FLOW	In Flow mode, the current flow is below the minimum set level
ALARM 13	HI FLOW	In Flow mode, the current flow is above the maximum set level
ALARM 14	LO FLOWT	In Flow mode, the current flow is below the minimum set level because no flow input signal has been received for the timeout time. This generally indicates a broken sensor or that the system being monitored is switched off
ALARM 15	UNCODED FAIL	An unknown Internal error has occurred. Try resetting the unit. If the error re-occurs, the unit must be returned to Dropsa for inspection.

11. TECHNICAL SPECIFICATIONS

OPERATING VOLTAGE	12/24 Vdc/ac (1639141) 110V~ (1639142) 230V~ (1639140)
Power consumption	2,5W
Temperature Operating Range	- 5 °C ÷ + 70 °C
Permissible Temperature storage range	- 20°C ÷ + 80 °C)
Operating Relative Humidity	90% max



Note : To ensure that seal of the casing is guaranteed alone use appropriate cable glands that provide adequate protection.. If the cable glands are not sufficient in number for your configuration, use a multi-connector solution and a cabling harness that will ensure adequate sealing and avoid torsion and tension on the cable.

12. MAINTENANCE PROCEDURES

VIP05 has been designed not to require any regular maintenance. We recommend to occasionally clean the unit with a damp cloth, not using solvents

The battery life is approximately 10 years. In the event that the battery needs to be replaced you should note that there are two possible battery types.

- a) A Soldered type battery that must be removed and re-soldered.
This type of battery can be obtain from Panasonic PART NUMBER BT-CR2032-H, easily purchased all over the world.
- b) The replaceable type battery can be simply removed and replaced.
This type of battery can be obtain from Panasonic PART NUMBER CR2032, easily purchased all over the world.

13. DISPOSAL PROCEDURES

The unit does not contain any harmful substances and should be disposed of following local regulations, including any recycling information indicated on the components themselves.

14. ORDERING INFORMATION

VIP5

PART NUMBER	DESCRIPTION
1639140	VIP5 230V AC 50/60 Hz
1639141	VIP5 12/24V DC/AC
1639142	VIP5 110V AC 50/60 Hz
1639144	VIP5 PANEL MOUNT 230V AC 50/60 Hz
1639145	VIP5 PANEL MOUNT 12/24V DC/AC
1639147	VIP5 PANEL MOUNT 110V AC 50/60 Hz
1639150	VIP5 STEEL BOX 230V 1PH 50/60 Hz
1639151	VIP5 STEEL BOX 230V 3PH 50/60 Hz
1639152	VIP5 STEEL BOX 400V 3PH 50 Hz
1639153	VIP5 STEEL BOX 500V 3PH 50 Hz

15. MOVING AND SHIPPING

Use suitable padded packaging when shipping the VIP5 controller and ensure that no damage has been sustained before reinstallation.

16. OPERATING PRECAUTIONS



ATTENTION: It is necessary to carefully read about the instructions and the risks involved in the use of lubrication machines.
The operator should make sure he fully understands the operating and safety procedures of the VIP5 controller and any connected machinery or devices.

Power supply

Any type of intervention must not be carried out before the unplugging of the machine from power supply.

Make sure that no one can start it up again during the intervention.

All the installed electric and electronic equipment, reservoirs and basic components must be grounded.

Flammability

The lubricant generally used in lubrication systems is not normally flammable.

However, it is advised to avoid contact with extremely hot substances or naked flames.

Pressure

Prior to any intervention, check the absence of residual pressure in any branch of the lubricant circuit as it may cause oil sprays when disassembling components or fittings.

Noise

The device does not produce excessive noise, less than 70 dB(A) .

18. WARRANTY

All products manufactured and marketed by Dropsa are warranted to be free of defects in material or workmanship for a period of at least 12 months from date of delivery.

Extended warranty coverage applies as follows.

Complete system installation by Dropsa: 24 Months.

All other components: 12 months from date of installation; if installed 6 months or more after ship date, warranty shall be maximum of 18 months from ship date.

If a fault develops, notify Dropsa giving:

- ✓ A complete description of the alleged malfunction
- ✓ The part number(s)
- ✓ Test record number where available (format xxxxxx-xxxxxx)
- ✓ Date of delivery
- ✓ Date of installation
- ✓ Operating conditions of subject product(s)

We will subsequently review this information and supply you with either servicing data or shipping instruction and returned materials authorization (RMA) which will have instructions on how to prepare the product for return.

Upon prepaid receipt of subject product to an authorized Dropsa Sales & Service location, we will then either repair or replace such product(s), at our option, and if determined to be a warranted defect, we will perform such necessary product repairs or replace such product(s) at our expense.

Dropsa reserves the right to charge an administration fee if the product(s) returned are found to be not defective.

This limited warranty does not cover any products, damages or injuries resulting from misuse, neglect, normal expected wear, chemically caused corrosion, improper installation or operation contrary to factory recommendation.

Nor does it cover equipment that has been modified, tampered with or altered without authorization.

Consumables and perishable products are excluded from this or any other warranty.

No other extended liabilities are stated or implied and this warranty in no event covers incidental or consequential damages, injuries or costs resulting from any such defective product(s).

The use of Dropsa product(s) implies the acceptance of our warranty conditions. Modifications to our standard warranty must be in made in writing and approved by Dropsa.



Dropsa Spa
Via Benedetto Croce, 1
20090 Vimodrone (MI)
Italy

Tel.: (+39) 02. 250.79.1
Fax Sales: (+39) 02. 250.79.767
E-mail: sales@dropsa.it
Web site: <http://www.dropsa.com>



DICHIARAZIONE CE DI CONFORMITÀ Allegato II A, della Direttiva 2006/42/CE

La società Dropsa S.p.A., con sede legale in Milano, Via Besana,5

DICHIARA,

che la macchina denominata **"VIP5"** è conforme alle condizioni previste dalle Direttive CEE:

- 2006/95/CE Bassa Tensione
- 2004/108/CE Compatibilità elettromagnetica

poiché rispetta tutti i requisiti essenziali di sicurezza e sanitari che le concernono, ed in riferimento alle seguenti norme armonizzate:

- EN 60730 - 1
- EN 61000 - 4-2 / 4-3 / 4-5 / 4-6 / 4-11

COPIA DELL'ORIGINALE

Vimodrone (MI), Aprile 2009



CO:
eco

20. DISTRIBUTORS



Dropsa USA Inc.

50679 Wing Drive
Utica, Michigan 48315, USA
Tel: (+1) 586-566-1540
Fax: (+1) 586-566-1541
E-mail: salesusa@dropsa.com



Dropsa (UK) Ltd

Unit 6, Egham Business Village,
Egham, Surrey, TW20 8RB
Tel: (+44) 01784 - 431177
Fax: (+44) 01784-438598
E-mail: salesuk@dropsa.com



Dropsa S.p.A.

Via B. Croce,1
20090 Vimodrone (MI) Italy.
Tel: (+39) 02 - 250.79.1
Fax: (+39) 02 - 250.79.767
E-mail: sales@dropsa.it (Export)
E-mail: vendite@dropsa.it (National)



Dropsa GmbH

Volmerswerther Strasse 80
40221 Dusseldorf 1, Germany
Tel: (+49) 0211-39 40 11
Fax: (+49) 0211-39 40 13
E-mail: sales@dropsa.de



Dropsa China

Dropsa Lubrication Systems
(Shanghai) Co., Ltd
Tel: +86 (021) 67740275
Fax: +86 (021) 67740205
E-mail: china@dropsa.com



Dropsa France

23, Av.des.Morillons
Z.I. des Doucettes
91140 - Garges Les Gonesse
Tel: (+33) 01 39 93 00 33
Fax: (+33) 01 39 86 26 36
E-mail: salesfr@dropsa.com



Dropsa do Brazil

Rua Sobralia 171 Santo Amaro,
Sao Paulo, Brazil
Tel: (+55) 011-5631-0007
Fax: (+55) 011-5631-9408
E-mail: salesbr@dropsa.com



Polidrop S.A.

Av. Fabregada 26 - Pje Est.2
08907 L'Hospitalet de Llobregat
Barcelona, Spain
Tel: (+34) 93 260 22 50
Fax: (+34) 93 260 22 51
E-mail: engrase@polydrop.com



Dropsa Australia Ltd.

C20/148 Old Pittwater Road
Brookvale NSW 2100
Tel: +61 (0)2-9938-6644
Fax: +61 (0)2-9938-6611
E-mail: salesau@dropsa.com



Web site: <http://www.dropsa.com> - E-mail: sales@dropsa.com